

Fuses for Semiconductor Protection

European-British Standard



Standards: IEC 60 269-4

BS 88-4

Class: aR

Voltage ratings: AC 240 V – AC 700 V

Current ratings: 5 A – 900 A

Features / Benefits

- ▶ High interrupting rating 100 kA
- ▶ Voltage ratings AC 240 V – AC 700 V
- ▶ Protection of Power Semiconductors according to IEC 60269-4
- ▶ Complies with BS 88 Standard
available with striker for microswitch operation
- ▶ Class aR 5 A – 900 A according to IEC 60269-4



Fuses for Semiconductor Protection
European-British Standard

Selection Guide Fuses

Rated Voltage [V]	Size	Part No.	Selector Guide [Page]	Techn. Data [Page]
240	8.4 x 38	50 076 06	URE 3	URE 12
240	17.5 x 41.8	50 053 06	URE 4	URE 13
240	35 x 59	50 054 06	URE 5	URE 14
240	2 x 35 x 59	50 071 06	URE 6	URE 15
690	8.4 x 64.3	50 077 06	URE 7	URE 16
690	17.5 x 63.5	50 073 06	URE 8	URE 17
690	35 x 85	50 074 06	URE 9	URE 18
690	2 x 35 x 85	50 075 06	URE 10	URE 19
690	000 DIN 85	20 561 20	URE 11	URE 22
690	000 DIN 85	20 561 22	URE 11	URE 22
690	000 DIN 85	20 563 20	URE 12	URE 23
690	000 DIN 85	20 563 22	URE 12	URE 23
690/700	000	20 559 20	URE 13	URE 24
690/700	000	20 559 21	URE 13	URE 24

Selection Guide Set of Mounting Clips for Indicator Fuse

Size [mm]	Part No.	Techn. Data [Page]
17.5	58 053 04	URE 25
35	58 054 04	URE 25

Selection Guide Indicator Fuse

Rated Voltage [V]	Part No.	Techn. Data [Page]
240	58 053 07	URE 25
690	58 073 07	URE 25

Selection Guide Microswitch

Rated Voltage [V]	Part No.	Techn. Data [Page]
250 V	58 053 05.1	URE 25



Fuses for Semiconductor Protection
European-British Standard

Size 8.4 x 38 mm	Rated Voltage AC 240 V	Standard BS 88-4
----------------------------	----------------------------------	----------------------------

Rated Current [A]	Part No.	UL Rec.	Weight [kg/1]	Pack
5	50 076 06.5		0.005	50
6	50 076 06.6		0.005	50
10	50 076 06.10		0.005	50
12	50 076 06.12		0.005	50
16	50 076 06.16		0.005	50
20	50 076 06.20		0.005	50

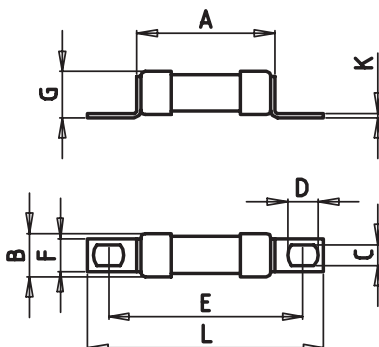

A	1.06" (27 mm)
B	0.33" (8.4 mm)
C	0.16" (4 mm)
D	0.24" (6 mm)
E	1.50" (38 mm)
F	0.25" (6.4 mm)
G	0.35" (9 mm)
K	0.03" (0.8 mm)
L	1.80" (46 mm)



Fuses for Semiconductor Protection
European-British Standard

Size
17.5 x 41.8 mm

Rated Voltage
AC 240 V

Standard
BS 88-4

Rated Current [A]	Part No.	UL Rec.	Weight [kg/1]	Pack
25	50 053 06.25		0.032	10
32	50 053 06.32		0.032	10
35	50 053 06.35		0.032	10
40	50 053 06.40		0.032	10
50	50 053 06.50		0.032	10
63	50 053 06.63		0.032	10
80	50 053 06.80		0.032	10
100	50 053 06.100		0.032	10
125	50 053 06.125		0.032	10
160	50 053 06.160		0.032	10
180	50 053 06.180		0.032	10

A	1.02" (26 mm)
B	0.70" (17.5 mm)
C	0.25" (6.35 mm)
D	0.30" (8 mm)
E	1.57" (40 mm)
F	0.50" (13 mm)
G	0.73" (18.5 mm)
K	0.10" (2.5 mm)
L	2.17" (55 mm)

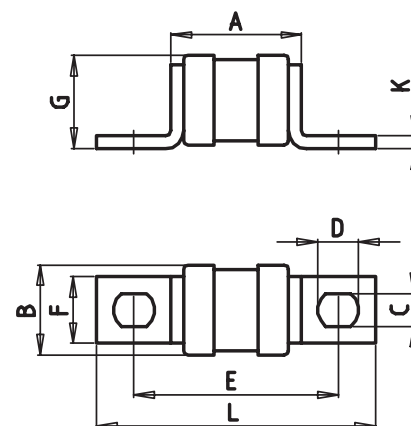



Fuses for Semiconductor Protection
European-British Standard

Size **35 x 59 mm** Rated Voltage **AC 240 V** Standard **BS 88-4**

Rated Current [A]	Part No.	UL Rec.	Weight [kg/1]	Pack
160	50 054 06.160		0.15	2
200	50 054 06.200		0.15	2
250	50 054 06.250		0.15	2
315	50 054 06.315		0.15	2
355	50 054 06.355		0.15	2
400	50 054 06.400		0.15	2
450	50 054 06.450		0.15	2

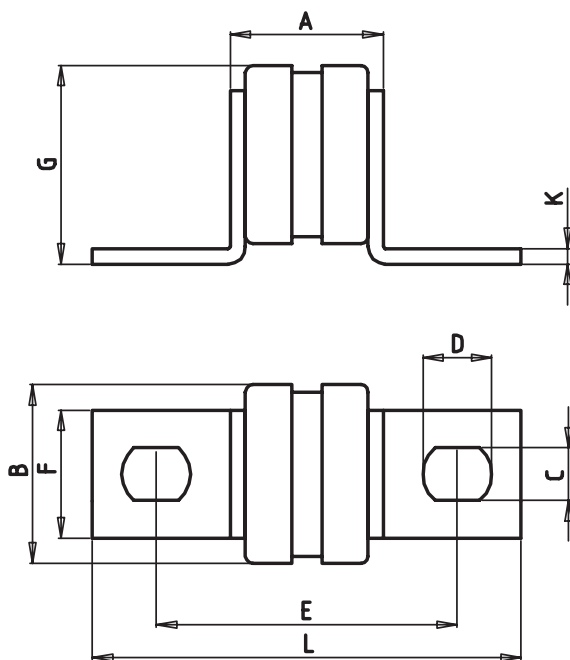

A	1.22" (31 mm)
B	1.38" (35 mm)
C	0.40" (10.3 mm)
D	0.53" (13.5 mm)
E	2.32" (59 mm)
F	0.98" (25 mm)
G	1.54" (39 mm)
K	0.12" (3 mm)
L	3.30" (84 mm)



Fuses for Semiconductor Protection
European-British Standard

Size
2 x 35 x 59 mm

Rated Voltage
AC 240 V

Standard
BS 88-4

Rated Current [A]	Part No.	UL Rec.	Weight [kg/1]	Pack
300	50 071 06.300		0.29	1
350	50 071 06.350		0.29	1
400	50 071 06.400		0.29	1
450	50 071 06.450		0.29	1
500	50 071 06.500		0.29	1
630	50 071 06.630		0.29	1
710	50 071 06.710		0.29	1
800	50 071 06.800		0.29	1
900	50 071 06.900		0.29	1

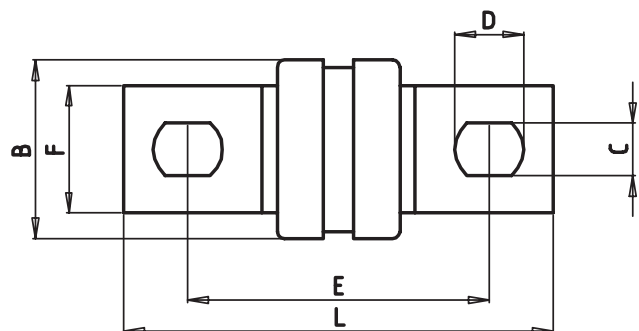
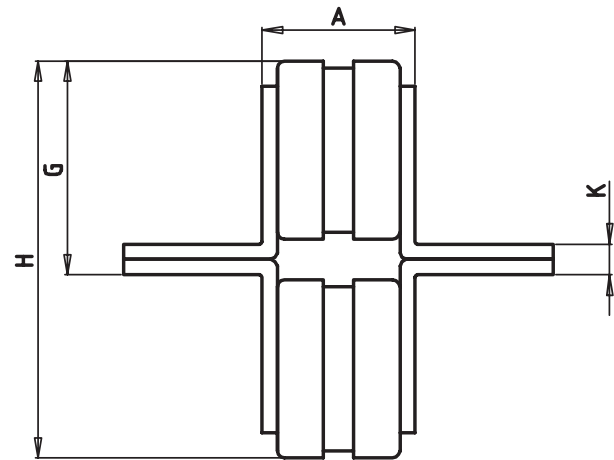

- A** 1.22" (31 mm)
- B** 1.38" (35 mm)
- C** 0.40" (10.3 mm)
- D** 0.53" (13.5 mm)
- E** 2.32" (59 mm)
- F** 1.0" (25 mm)
- G** 1.65" (42 mm)
- H** 1.65" (78 mm)
- K** 0.24" (6 mm)
- L** 3.30" (84 mm)



Fuses for Semiconductor Protection
European-British Standard

Size **8.4 x 64.3 mm** Rated Voltage **AC 690 V** Standard **BS 88-4**

Rated Current [A]	Part No.	UL Rec.	Weight [kg/1]	Pack
5	50 077 06.5		0.008	50
6	50 077 06.6		0.008	50
10	50 077 06.10		0.008	50
12	50 077 06.12		0.008	50
16	50 077 06.16		0.008	50
20	50 077 06.20		0.008	50

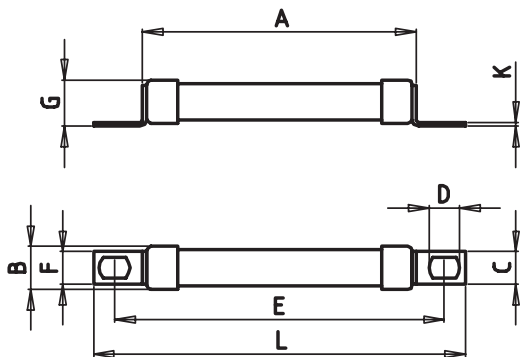

A	2.13" (54 mm)
B	0.33" (8.4 mm)
C	0.16" (4 mm)
D	0.24" (6 mm)
E	2.52" (64 mm)
F	0.25" (6.4 mm)
G	0.35" (9 mm)
K	0.03" (0.8 mm)
L	2.87" (73 mm)



Fuses for Semiconductor Protection
European-British Standard

Size
17.5 x 63.5 mm

Rated Voltage
AC 690 V

Standard
BS 88-4

Rated Current [A]	Part No.	UL Rec.	Weight [kg/1]	Pack
25	50 073 06.25		0.042	10
32	50 073 06.32		0.042	10
40	50 073 06.40		0.042	10
50	50 073 06.50		0.042	10
63	50 073 06.63		0.042	10
80	50 073 06.80		0.042	10
100	50 073 06.100		0.042	10

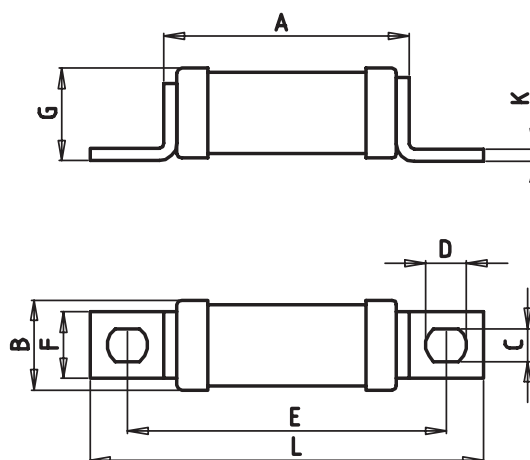

A	1.90" (48 mm)
B	0.70" (17.5 mm)
C	0.25" (6.35 mm)
D	0.30" (8 mm)
E	2.48" (63 mm)
F	0.50" (13 mm)
G	0.73" (18.5 mm)
K	0.10" (2.5 mm)
L	3.03" (77 mm)



Fuses for Semiconductor Protection
European-British Standard

Size **35 x 85 mm** Rated Voltage **AC 690 V** Standard **BS 88-4**

Rated Current [A]	Part No.	UL Rec.	Weight [kg/1]	Pack
100	50 074 06.100		0.19	3
125	50 074 06.125		0.19	3
160	50 074 06.160		0.19	3
200	50 074 06.200		0.19	3
250	50 074 06.250		0.19	3
315	50 074 06.315		0.19	3
355	50 074 06.355		0.19	3

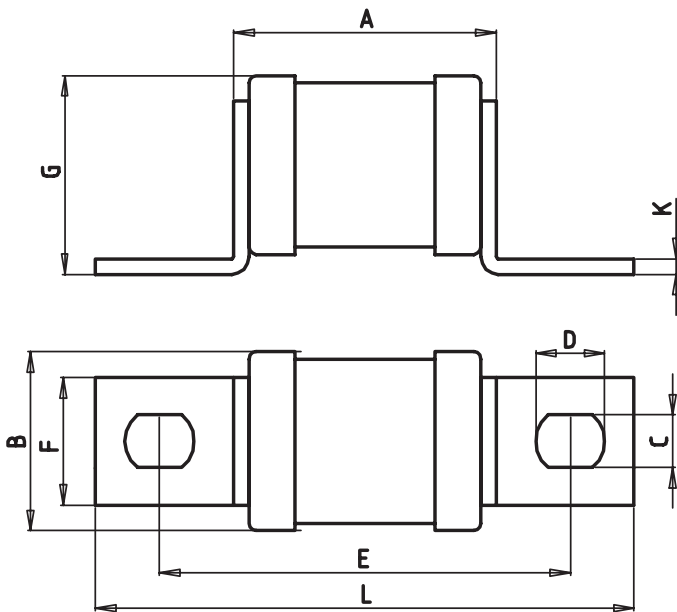

A	2.05" (52 mm)
B	1.38" (35 mm)
C	0.40" (10.3 mm)
D	0.53" (13.5 mm)
E	3.15" (80 mm)
F	0.98" (25 mm)
G	1.54" (39 mm)
K	0.12" (3 mm)
L	4.13" (105 mm)



Fuses for Semiconductor Protection
European-British Standard

Size
2 x 35 x 85 mm

Rated Voltage
AC 690 V

Standard
BS 88-4

Rated Current [A]	Part No.	UL Rec.	Weight [kg/1]	Pack
315	50 075 06.315		0.37	1
355	50 075 06.355		0.37	1
400	50 075 06.400		0.37	1
450	50 075 06.450		0.37	1
500	50 075 06.500		0.37	1
630	50 075 06.630		0.37	1
710	50 075 06.710		0.37	1

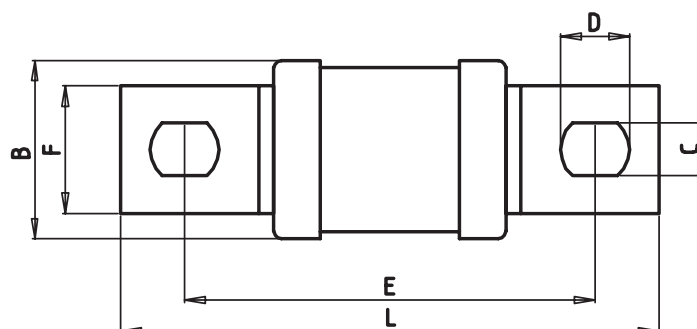
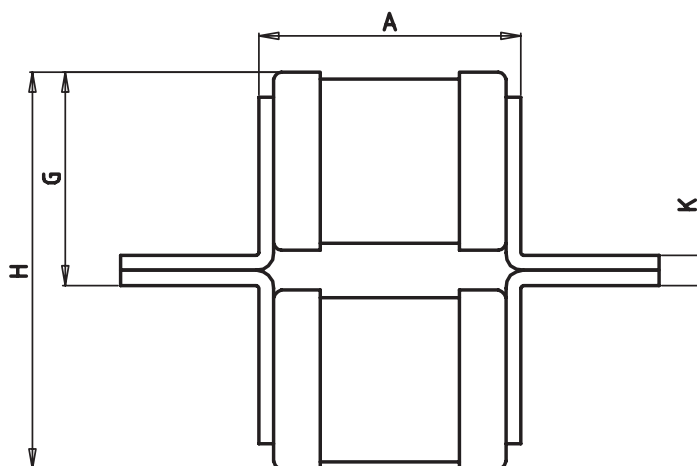

- A 2.05" (52 mm)
- B 1.38" (35 mm)
- C 0.40" (10.3 mm)
- D 0.53" (13.5 mm)
- E 3.15" (80 mm)
- F 0.98" (25 mm)
- G 1.65" (42 mm)
- H 3.07" (78 mm)
- K 0.24" (6 mm)
- L 4.12" (105 mm)



Fuses for Semiconductor Protection
European-British Standard

Size **000 DIN 85** Rated Voltage **AC 690 V** Standard **IEC 60269-4**

Rated Current [A]	Part No.	Part No. without Indicator	UL Rec.	Weight [kg/1]	Pack
110	20 561 22.110	20 561 20.110		0.19	6
125	20 561 22.125	20 561 20.125		0.19	6
150	20 561 22.150	20 561 20.150		0.19	6
160	20 561 22.160	20 561 20.160		0.19	6
180	20 561 22.180	20 561 20.180		0.19	6
200	20 561 22.200	20 561 20.200		0.19	6
250	20 561 22.250	20 561 20.250		0.19	6
315	20 561 22.315	20 561 20.315		0.19	6
350	20 561 22.350	20 561 20.350		0.19	6
400	20 561 22.400	20 561 20.400		0.19	6

Part No. 20 561 20

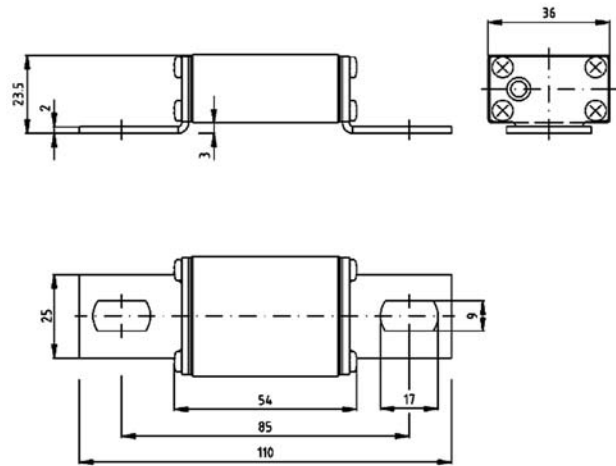

Part No. 20 561 22

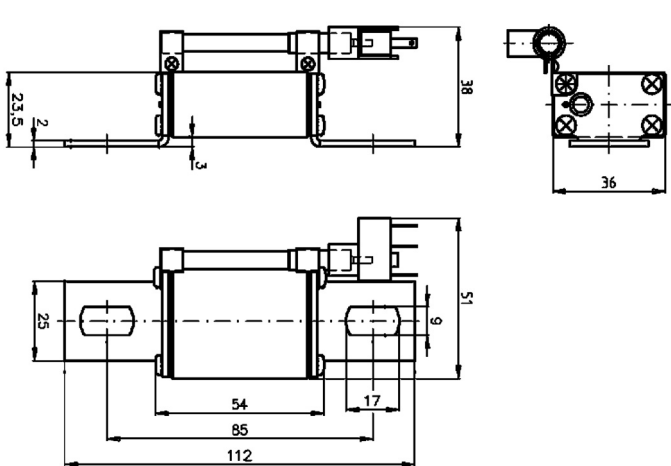



Fuses for Semiconductor Protection
European-British Standard

Size **000 DIN 85** Rated Voltage **AC 690 V** Standard **IC 60269-4**

Rated Current [A]	Part No.	Part No. without Indicator	UL Rec.	Weight [kg/1]	Pack
400	20 563 22.400	20 563 20.400		0.38	3
500	20 563 22.500	20 563 20.500		0.38	3
630	20 563 22.630	20 563 20.630		0.38	3
700	20 563 22.700	20 563 20.700		0.38	3
800	20 563 22.800	20 563 20.800		0.38	3

Part no. 20 563 20

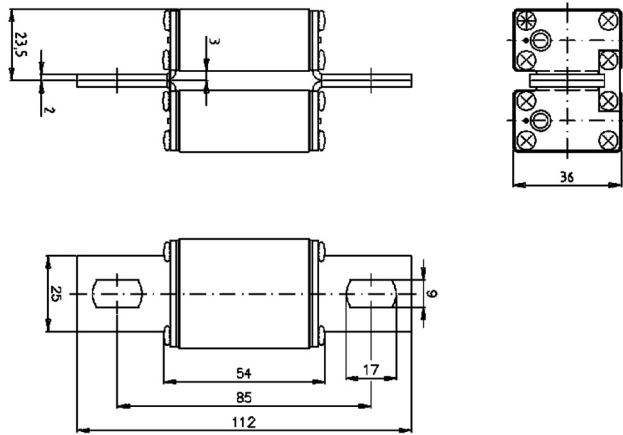

Part No. 20 563 22

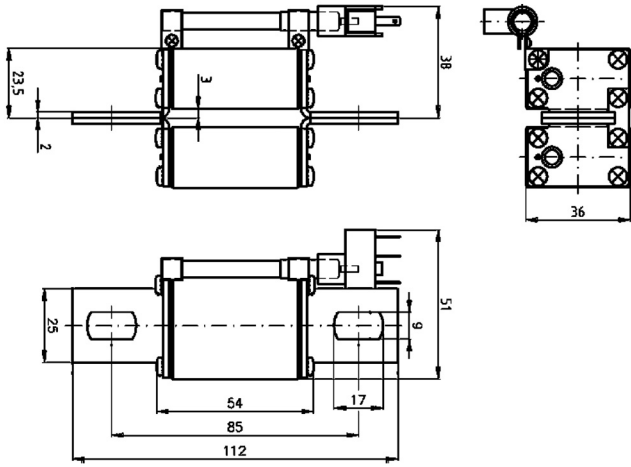



Fuses for Semiconductor Protection
European-British Standard

Size **000** Rated Voltage **AC 660/700 V** Standard **BS 88-4**

Rated current [A]	Part No.	Part No. without Indicator	UL Rec.	Weight [kg/1]	Pack
32	20 559 20.32	20 559 21.32	✓	0.17	6
35	20 559 20.35	20 559 21.35	✓	0.17	6
40	20 559 20.40	20 559 21.40	✓	0.17	6
50	20 559 20.50	20 559 21.50	✓	0.17	6
63	20 559 20.63	20 559 21.63	✓	0.17	6
80	20 559 20.80	20 559 21.80	✓	0.17	6
100	20 559 20.100	20 559 21.100	✓	0.17	6
160	20 559 20.160	20 559 21.160	✓	0.17	6
200	20 559 20.200	20 559 21.200	✓	0.17	6
250	20 559 20.250	20 559 21.250	✓	0.17	6
315	20 559 20.315	20 559 21.315	✓	0.17	6

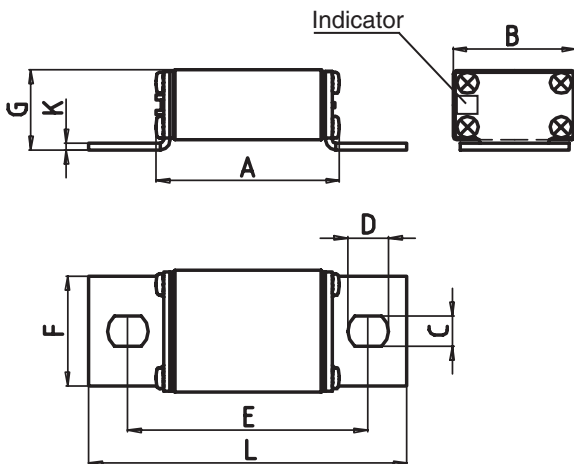

A _{max.}	2.13" (54 mm)
B	1.42" (36 mm)
C	0.35" (9 mm)
D	0.47" (12 mm)
E	2.76" (70 mm)
F	1.26" (32 mm)
G	0.93" (23.5 mm)
K	0.08" (2 mm)
L	3.70" (94 mm)

Size
8.4 x 38 mm

Rated Voltage
AC 240 V

Operating Class
aR

Rated Breaking Capacity
100 kA

Rated Current [A]	Part No.	Power Loss [W]	Pre-arcing I ² t-value [A ² s]	Total I ² t-value @ 240 V [A ² s]
5	50 076 06.5	1.5	1.7	9.5
6	50 076 06.6	1.7	2.9	16.0
10	50 076 06.10	3.3	4.2	24.0
12	50 076 06.12	2.0	8.0	41.0
16	50 076 06.16	2.4	18.0	92.0
20	50 076 06.20	3.3	25.0	130.0

Cut-Off Characteristics

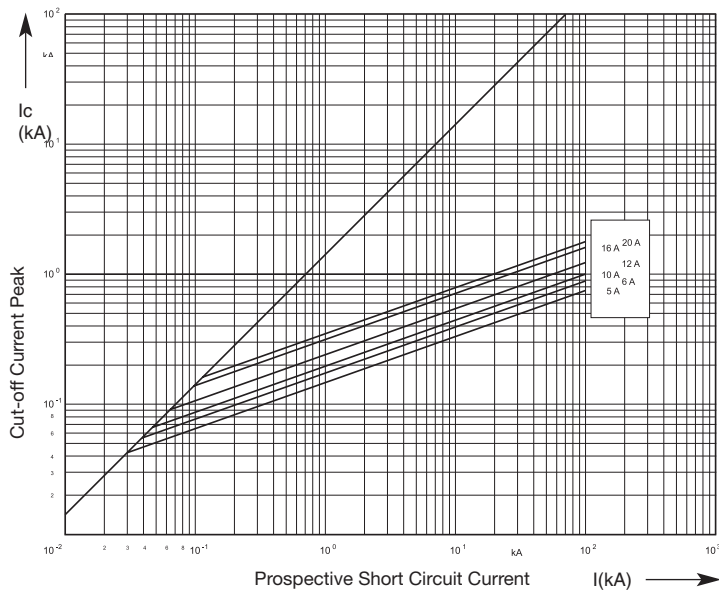

Time-Current Characteristics

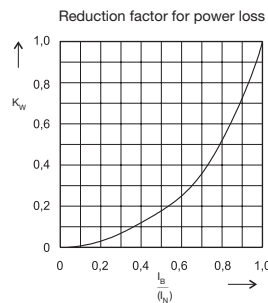
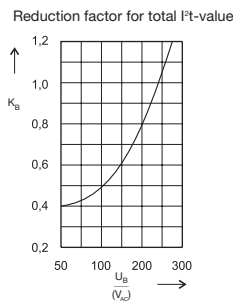
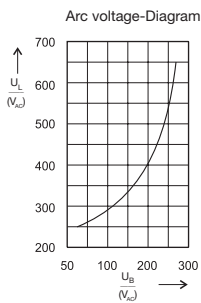
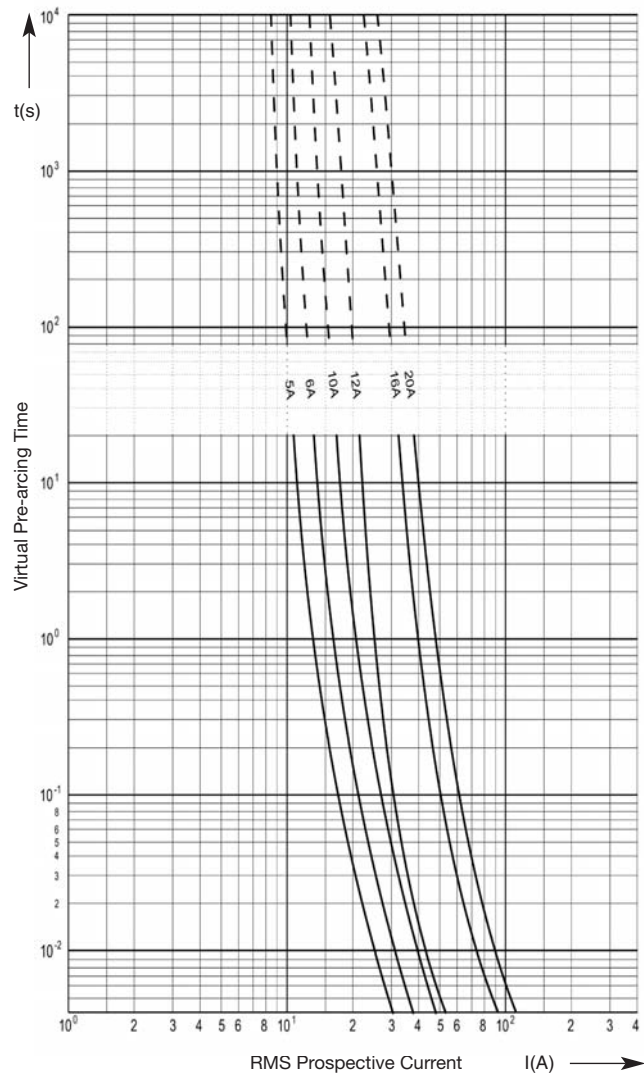

Size 17.5 x 41.8 mm	Rated Voltage AC 240 V	Operating Class aR	Rated Breaking Capacity 100 kA
-------------------------------	----------------------------------	------------------------------	--

Rated Current [A]	Part No.	Power Loss [W]	Pre-arcing I ² t-value [A ² s]	Total I ² t-value @ 240 V [A ² s]
25	50 053 06.25	3.6	39	260
32	50 053 06.32	4.5	40	270
35	50 053 06.35	5.0	63	430
40	50 053 06.40	5.3	100	700
50	50 053 06.50	6.7	130	900
63	50 053 06.63	7.7	250	1 700
75	50 053 06.75	9.4	330	2 300
80	50 053 06.80	9.7	420	2 900
100	50 053 06.100	12.7	620	4 300
125	50 053 06.125	16.0	1 000	6 800
160	50 053 06.160	22.0	1 500	10 200
180	50 053 06.180	24.0	2 300	15 700

Cut-Off Characteristics

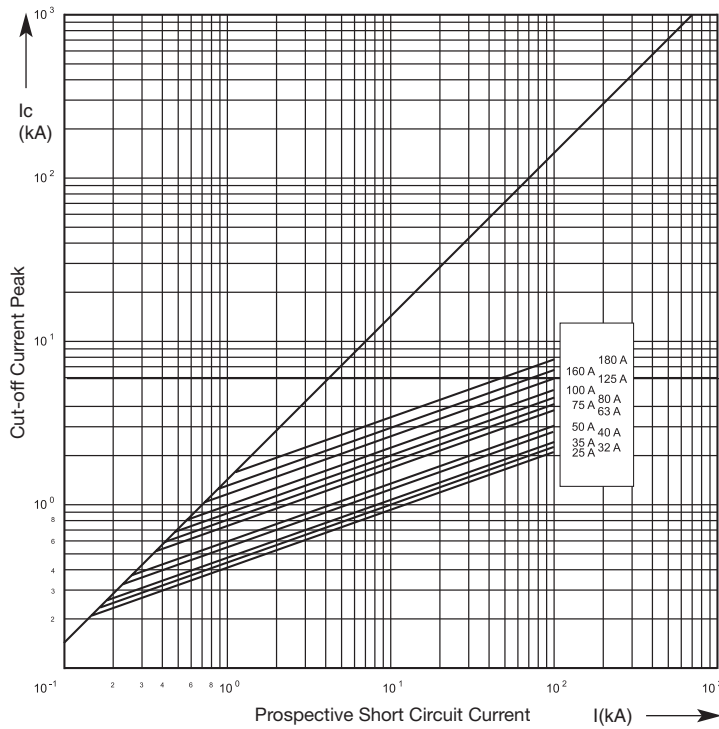

Time-Current Characteristics

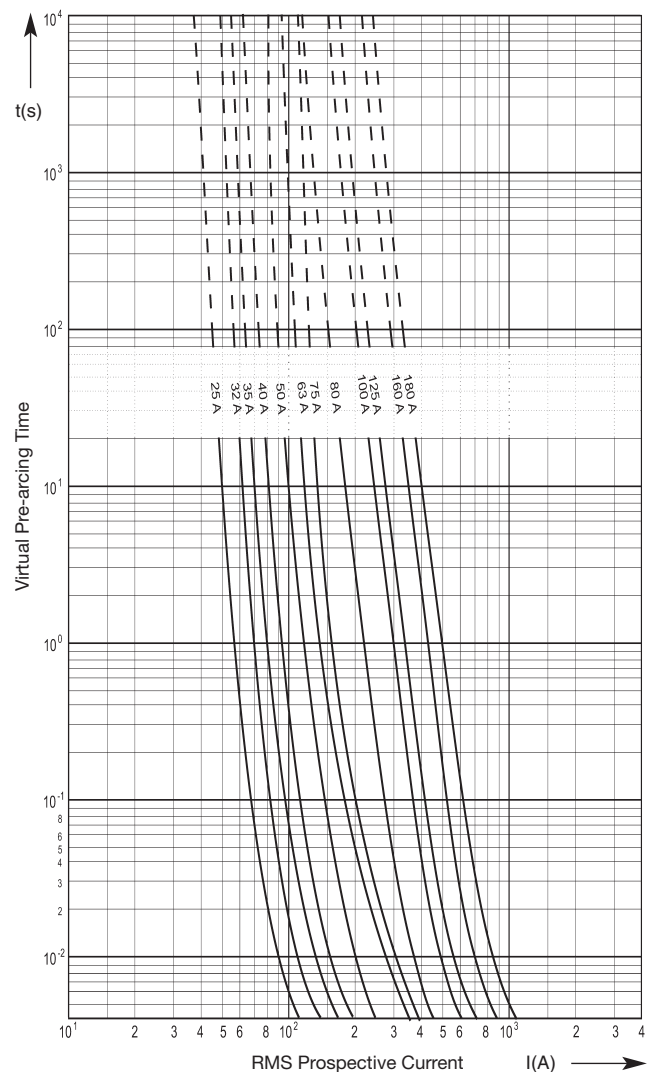

Arc voltage-Diagram

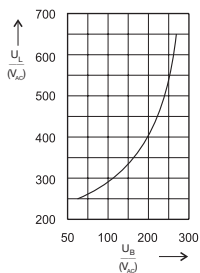

Reduction factor for total I²t-value

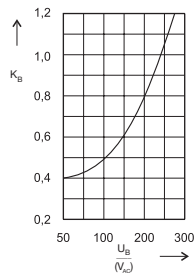

Reduction factor for power loss

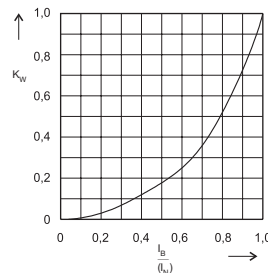

Size
35 x 59 mm

Rated Voltage
AC 240 V

Operating Class
aR

Rated Breaking Capacity
100 kA

Rated Current [A]	Part No.	Power Loss [W]	Pre-arcing I ² t-value [A ² s]	Total I ² t-value @ 240 V [A ² s]
160	50 054 06.160	23	1 300	8 000
200	50 054 06.200	27	2 500	15 300
250	50 054 06.250	34	4 600	28 000
315	50 054 06.315	36	7 800	48 000
355	50 054 06.355	38	11 800	72 000
400	50 054 06.400	40	18 500	113 000
450	50 054 06.450	46	26 600	163 000

Cut-Off Characteristics

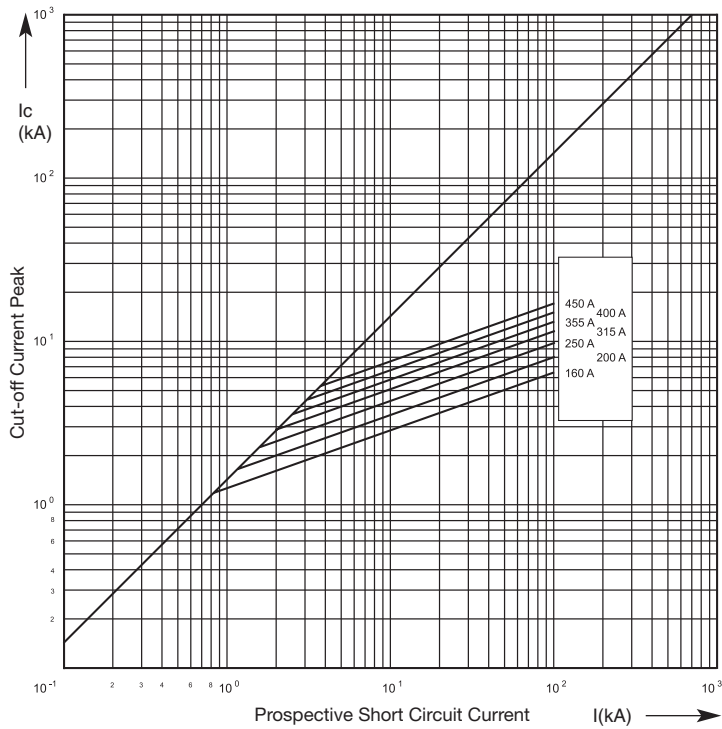

Time-Current Characteristics

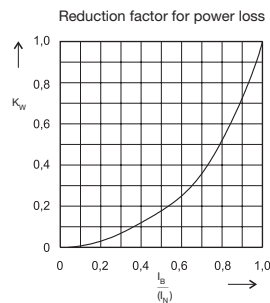
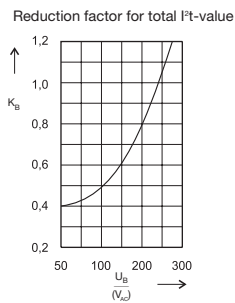
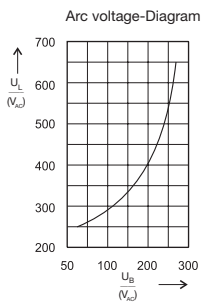
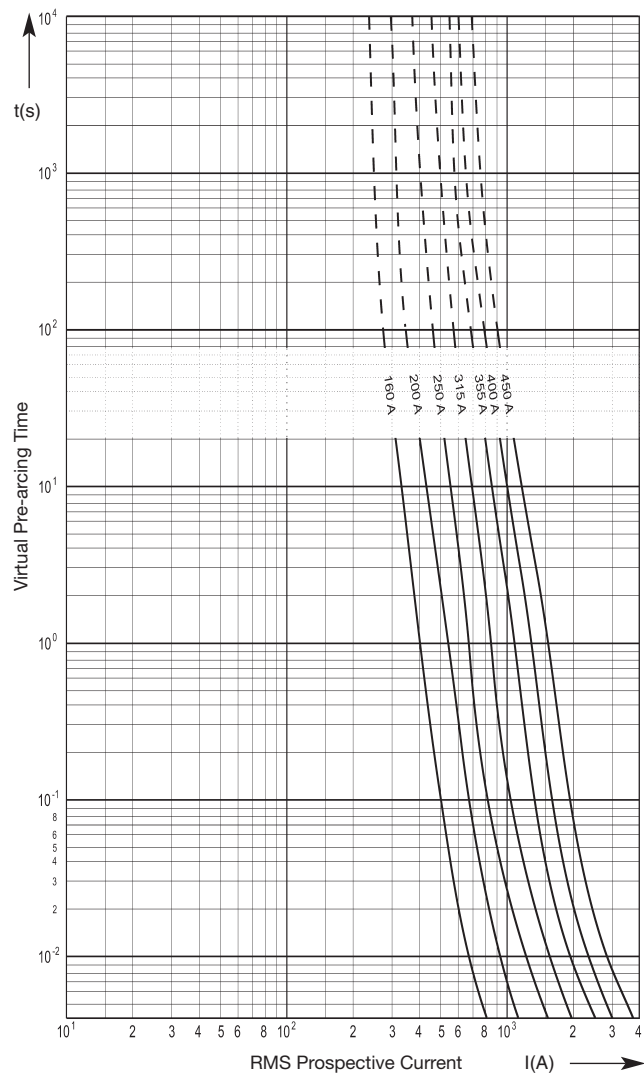

Size 2 x 35 x 59 mm	Rated Voltage AC 240 V	Operating Class aR	Rated Breaking Capacity 100 kA
-------------------------------	----------------------------------	------------------------------	--

Rated Current [A]	Part No.	Power Loss [W]	Pre-arcing I ² t-value [A ² s]	Total I ² t-value @ 240 V [A ² s]
400	50 071 06.400	55	10 000	61 000
450	50 071 06.450	56	19 000	116 000
500	50 071 06.500	59	27 000	165 000
630	50 071 06.630	62	50 000	305 000
710	50 071 06.710	72	70 000	427 000
800	50 071 06.800	74	106 000	647 000
900	50 071 06.900	90	150 000	915 000

Cut-Off Characteristics

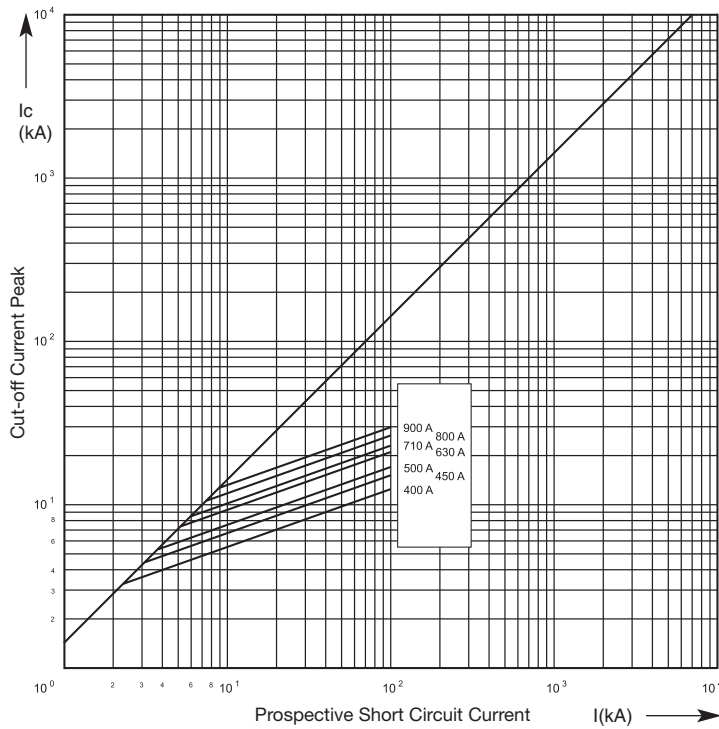

Time-Current Characteristics

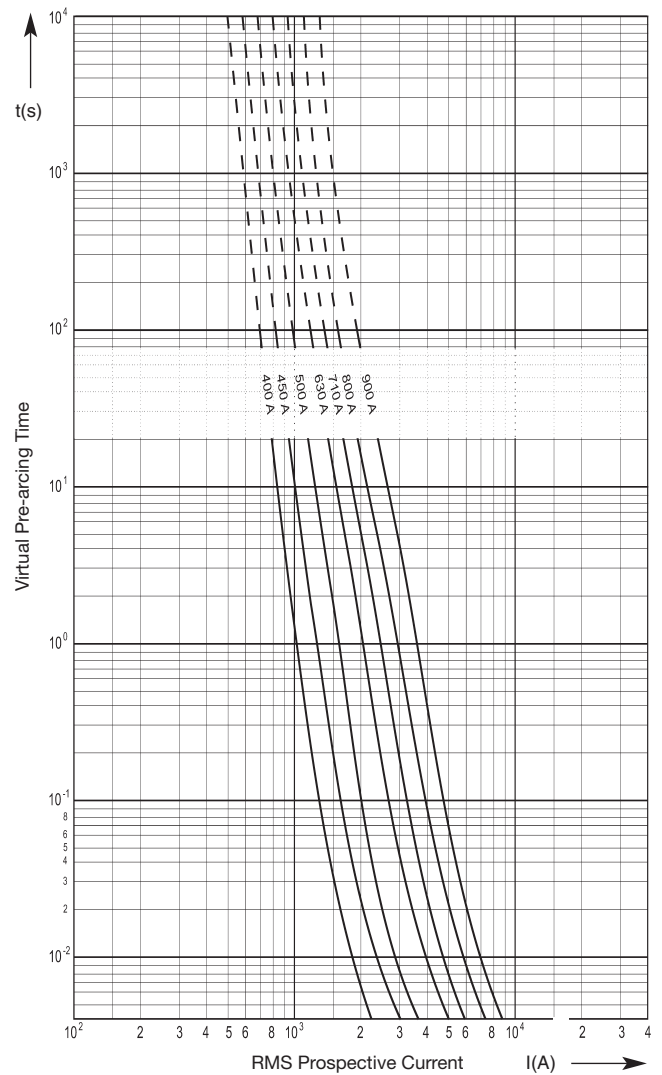

Arc voltage-Diagram

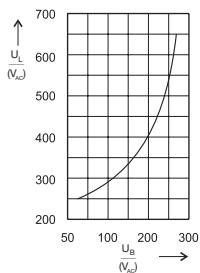

Reduction factor for total I²t-value

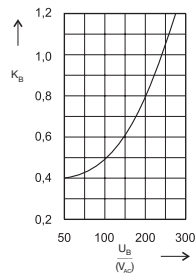

Reduction factor for power loss

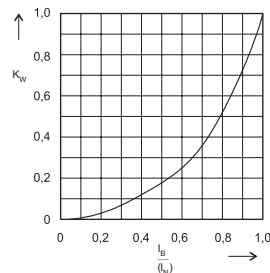

Size
8.4 x 64.3 mm

Rated Voltage
AC 690 V

Operating Class
aR

Rated Breaking Capacity
100 kA

Rated Current [A]	Part No.	Power Loss [W]	Pre-arcing I ² t-value [A ² s]	Total I ² t-value @ 690 V [A ² s]
6	50 077 06.6	3.2	3	20
10	50 077 06.10	3.7	8	53
12	50 077 06.12	3.9	11	77
16	50 077 06.16	5.5	18	120
20	50 077 06.20	7.5	32	215

Cut-Off Characteristics

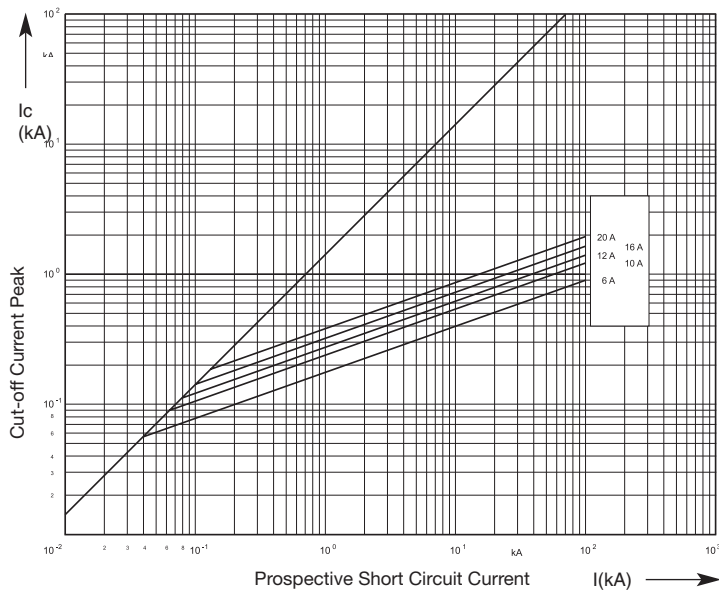

Time-Current Characteristics

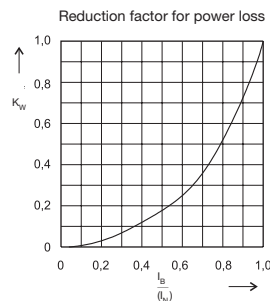
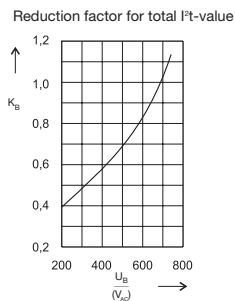
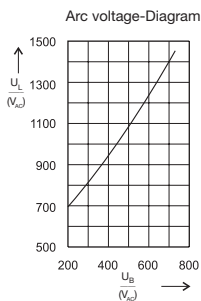
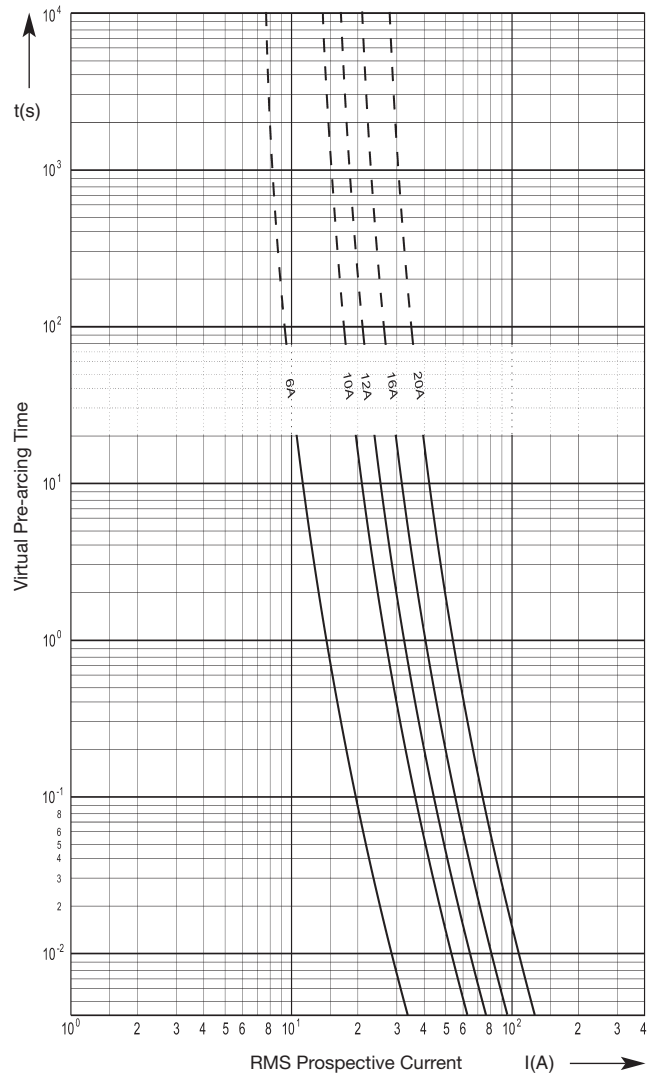

Size 17.5 x 63.5 mm	Rated Voltage AC 690 V	Operating Class aR	Rated Breaking Capacity 100 kA
-------------------------------	----------------------------------	------------------------------	--

Rated Current [A]	Part No.	Power Loss [W]	Pre-arcing I ² t-value [A ² s]	Total I ² t-value @ 690 V [A ² s]
25	50 073 06.25	7	25	110
32	50 073 06.32	9	50	210
35	50 073 06.35	10	60	260
40	50 073 06.40	11	80	330
50	50 073 06.50	12	190	780
63	50 073 06.63	15	290	1 200
80	50 073 06.80	18	420	1 700
100	50 073 06.100	23	740	3 100

Cut-Off Characteristics

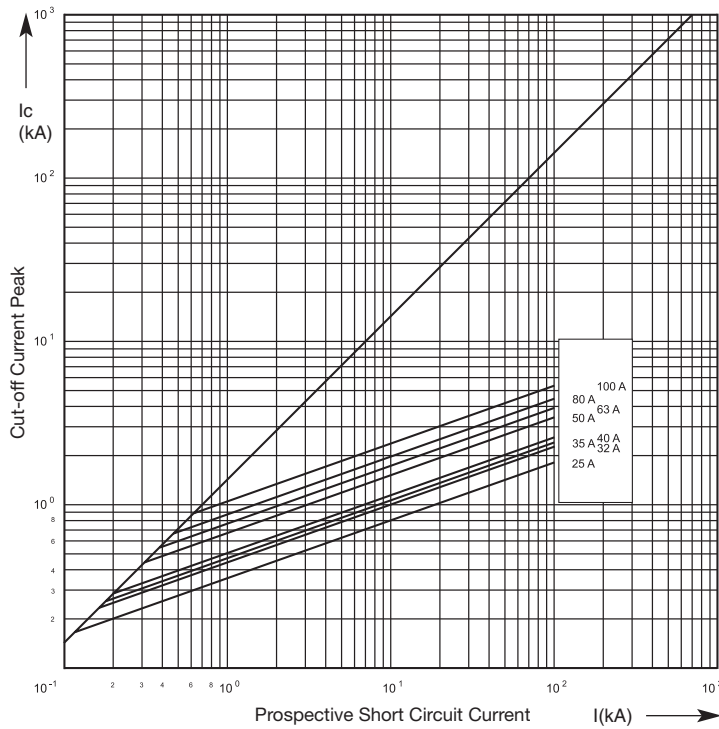

Time-Current Characteristics

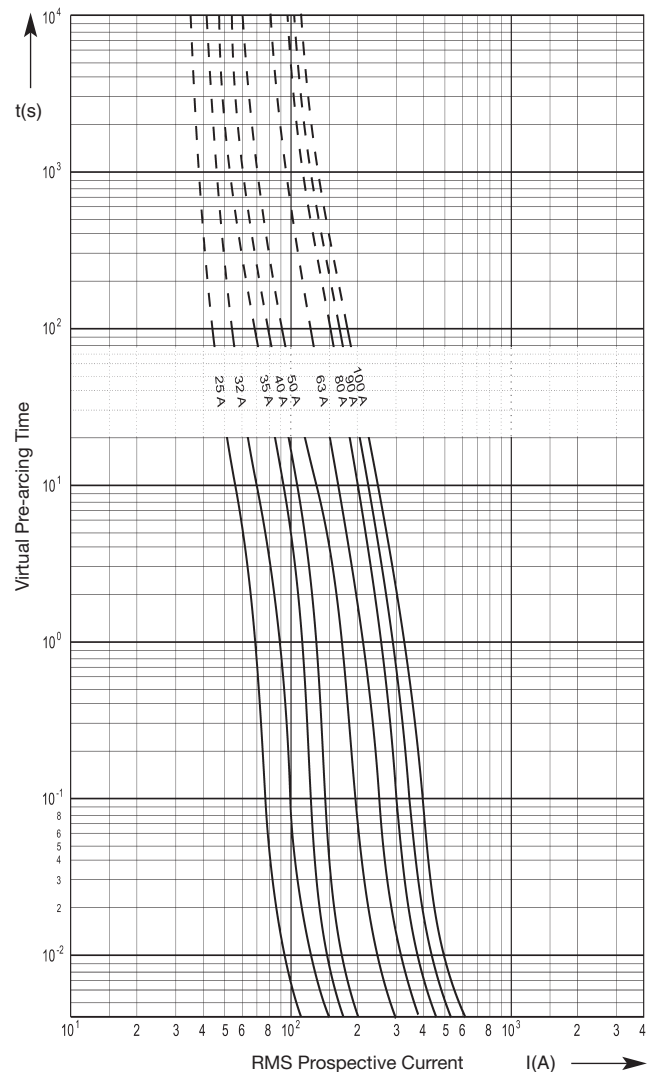

Arc voltage-Diagram

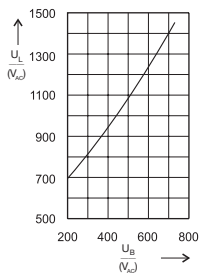

Reduction factor for total I²t-value

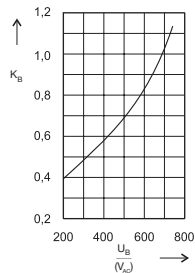

Reduction factor for power loss

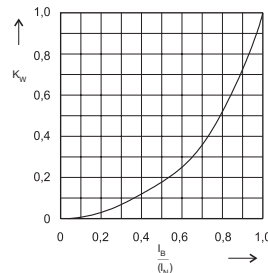

Size
35 x 85 mm

Rated Voltage
AC 690 V

Operating Class
aR

Rated Breaking Capacity
100 kA

Rated Current [A]	Part No.	Power Loss [W]	Pre-arcing I ² t-value [A ² s]	Total I ² t-value @ 690 V [A ² s]
100	50 074 06.100	22	1 000	6 500
125	50 074 06.125	29	1 700	11 000
160	50 074 06.160	30	4 000	26 000
200	50 074 06.200	31	9 000	58 000
250	50 074 06.250	40	18 000	116 000
315	50 074 06.315	44	27 000	173 000
355	50 074 06.355	56	36 000	231 000

Cut-Off Characteristics

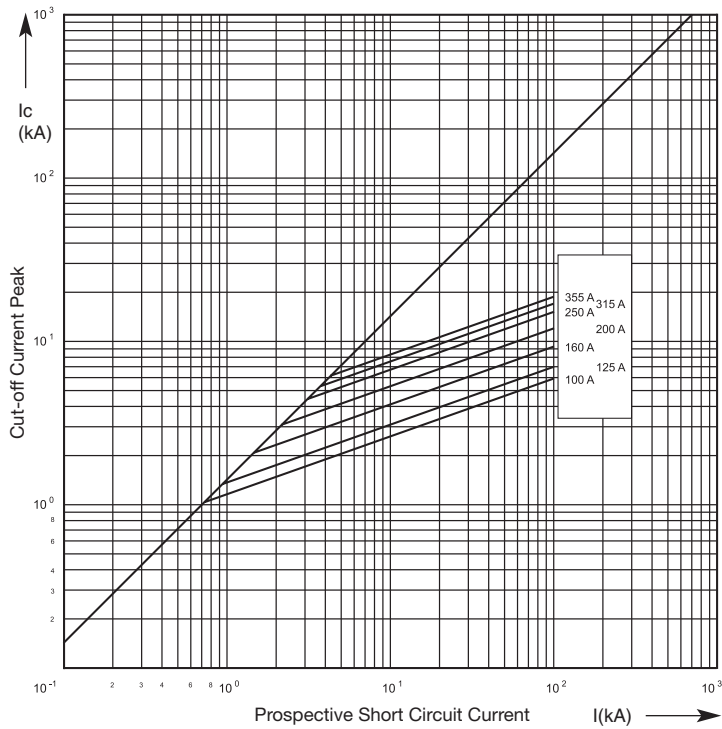

Time-Current Characteristics

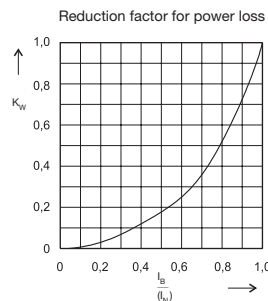
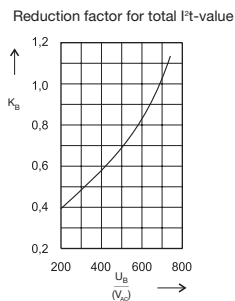
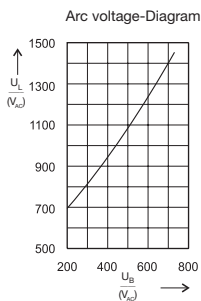
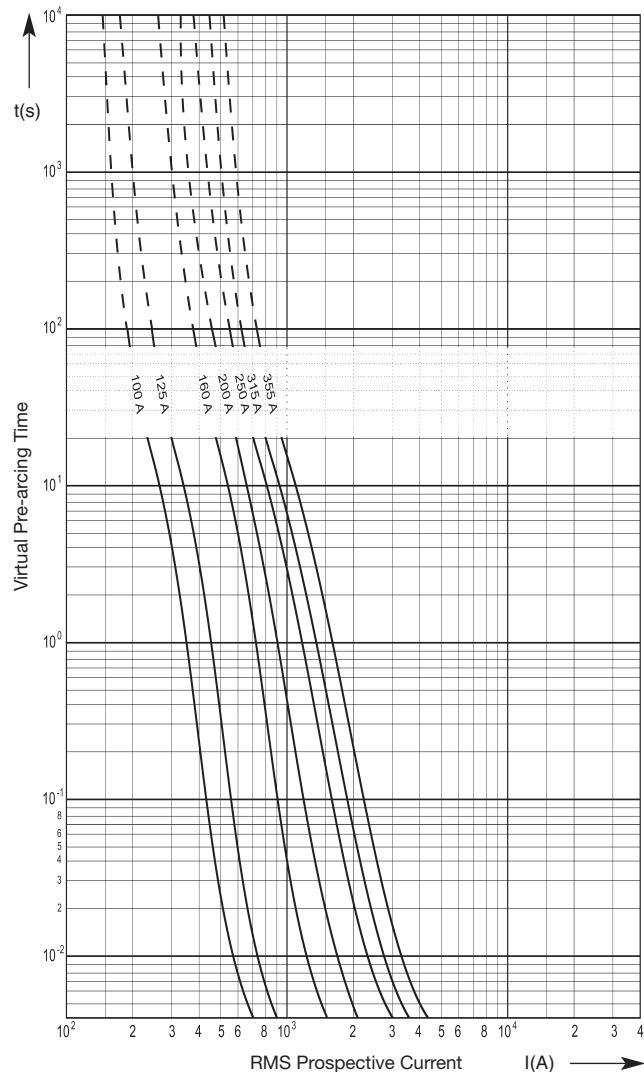

Size 2 x 35 x 85 mm	Rated Voltage AC 690 V	Operating Class aR	Rated Breaking Capacity 100 kA
-------------------------------	----------------------------------	------------------------------	--

Rated Current [A]	Part No.	Power Loss [W]	Pre-arcing I ² t-value [A ² s]	Total I ² t-value @ 690 V [A ² s]
315	50 075 06.315	48	18 500	119 000
355	50 075 06.355	55	22 300	143 000
400	50 075 06.400	58	26 100	167 000
450	50 075 06.450	63	52 300	335 000
500	50 075 06.500	68	70 100	449 000
630	50 075 06.630	87	106 000	679 000
710	50 075 06.710	104	145 000	928 000

Cut-Off Characteristics

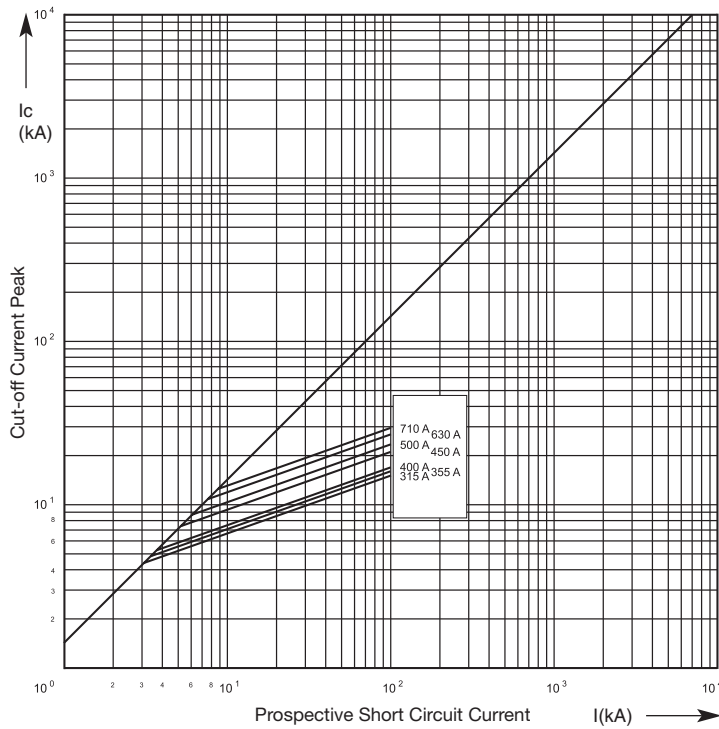

Time-Current Characteristics

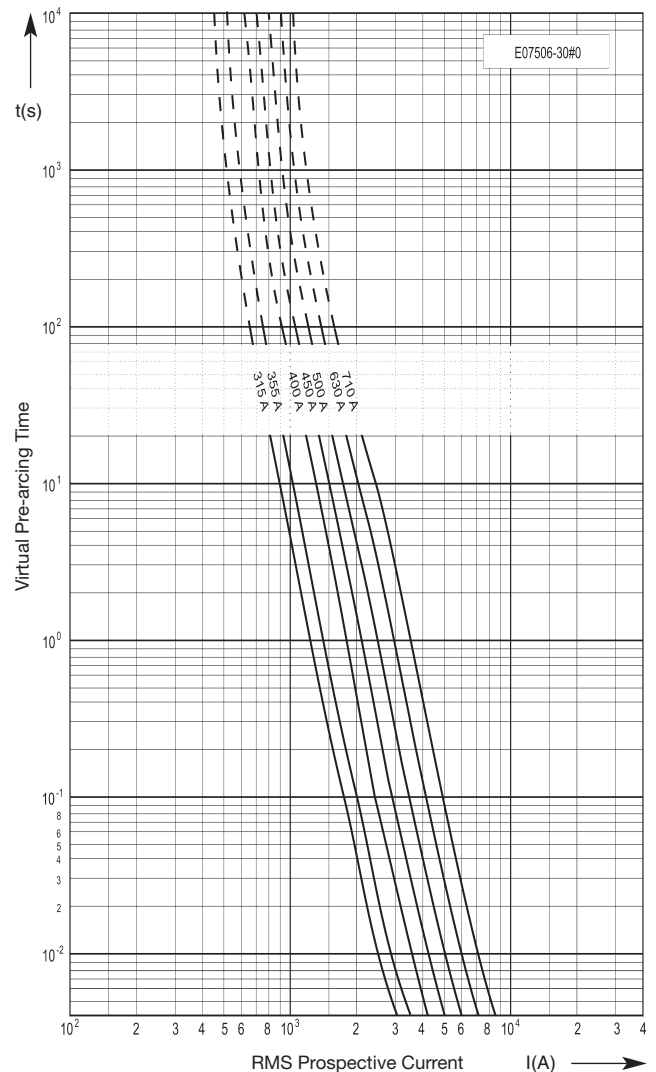

Arc voltage-Diagram

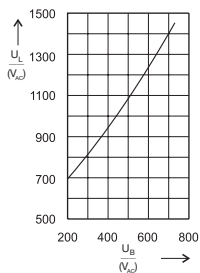

Reduction factor for total I²t-value

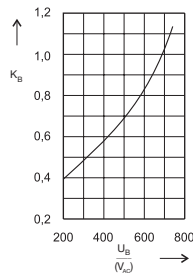

Reduction factor for power loss

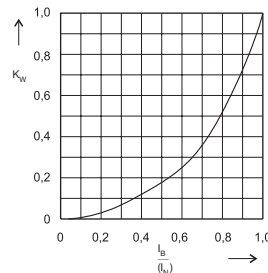

Size
000 DIN 85

Rated Voltage
AC 690

Operating Class
aR

Rated Breaking Capacity
120 kA

Rated Current [A]	Part No.	Part No. without Indicator	Power Loss [W]	Pre-arcing I ² t-value [A ² s]	Total I ² t-value [A ² s]
110	20 561 22.110	20 561 20.110	21	1 350	6 000
125	20 561 22.125	20 561 20.125	22	2 000	8 900
150	20 561 22.150	20 561 20.150	24	3 300	14 000
160	20 561 22.160	20 561 20.160	27	3 700	16 000
180	20 561 22.180	20 561 20.180	30	5 400	23 000
200	20 561 22.200	20 561 20.200	31	11 200	47 000
250	20 561 22.250	20 561 20.250	32	14 900	63 000
280	20 561 22.280	20 561 20.280	44	17 000	70 000
300	20 561 22.300	20 561 20.300	48	18 000	73 000
315	20 561 22.315	20 561 20.315	50	19 200	77 000
350	20 561 22.350	20 561 20.350	56	23 800	76 000
400	20 561 22.400	20 561 20.400	70	32 100	101 000

Cut-Off Characteristics

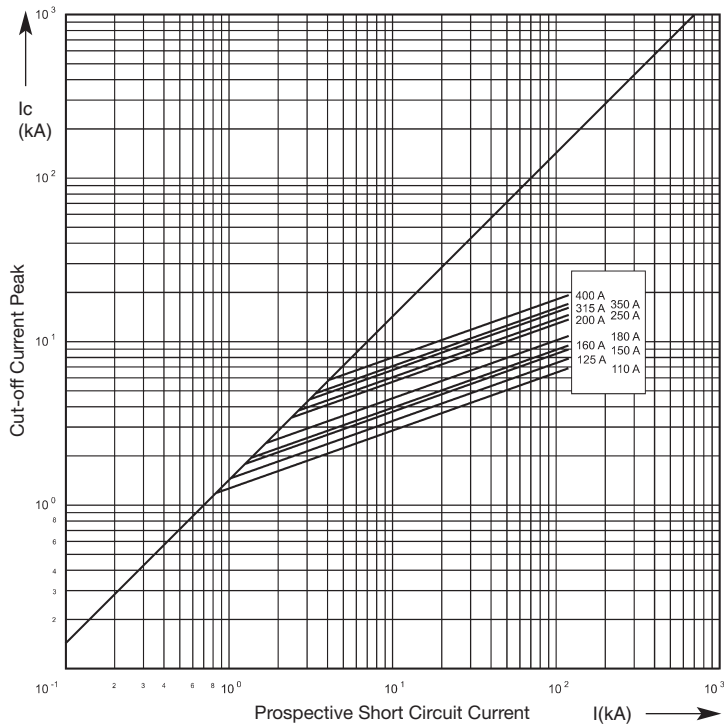

Time-Current Characteristics

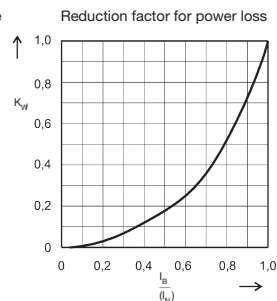
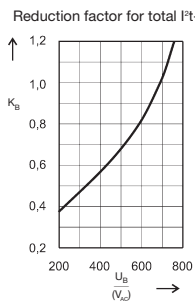
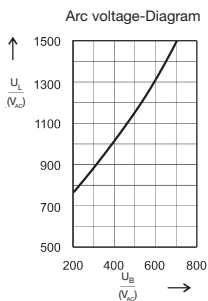
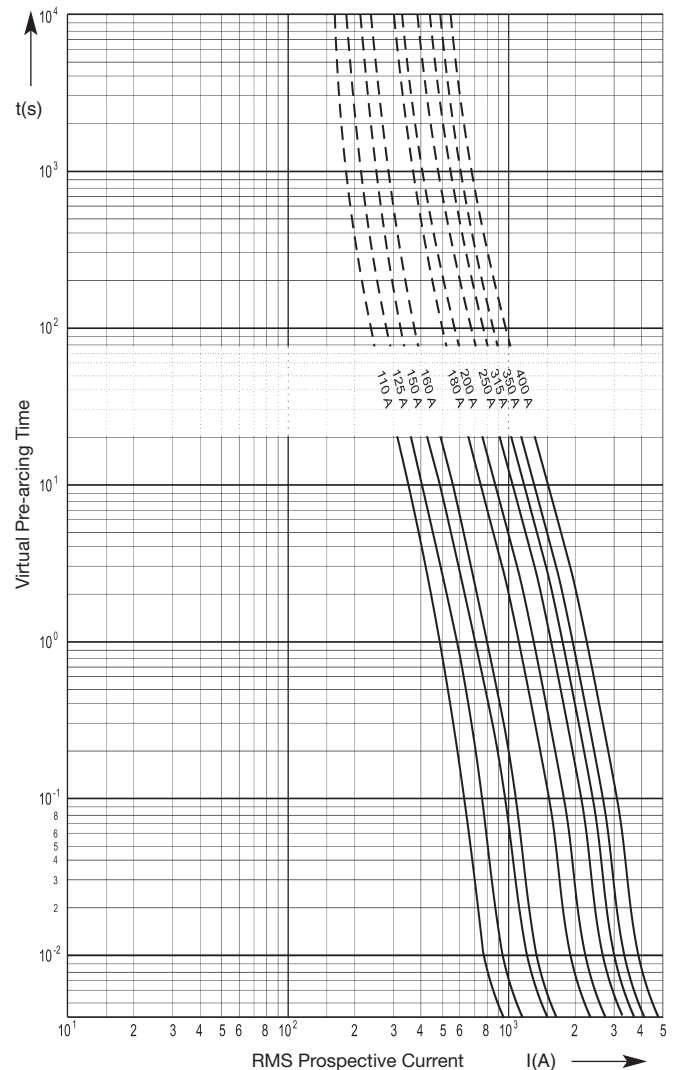

Size 000 DIN 85	Rated Voltage AC 690	Operating Class aR	Rated Breaking Capacity 120 kA
---------------------------	--------------------------------	------------------------------	--

Rated Current [A]	Part No.	Part No. without Indicator	Power Loss [W]	Pre-arcing I ² t-value [A ² s]	Total I ² t-value [A ² s]
400	20 563 22.400	20 563 20.400	65	44 800	188 000
450	20 563 22.450	20 563 20.450	68	52 000	220 000
500	20 563 22.500	20 563 20.500	69	59 600	252 000
630	20 563 22.630	20 563 20.630	105	76 800	308 000
700	20 563 22.700	20 563 20.700	118	95 200	304 000
800	20 563 22.800	20 563 20.800	147	129 000	404 000

Cut-Off Characteristics

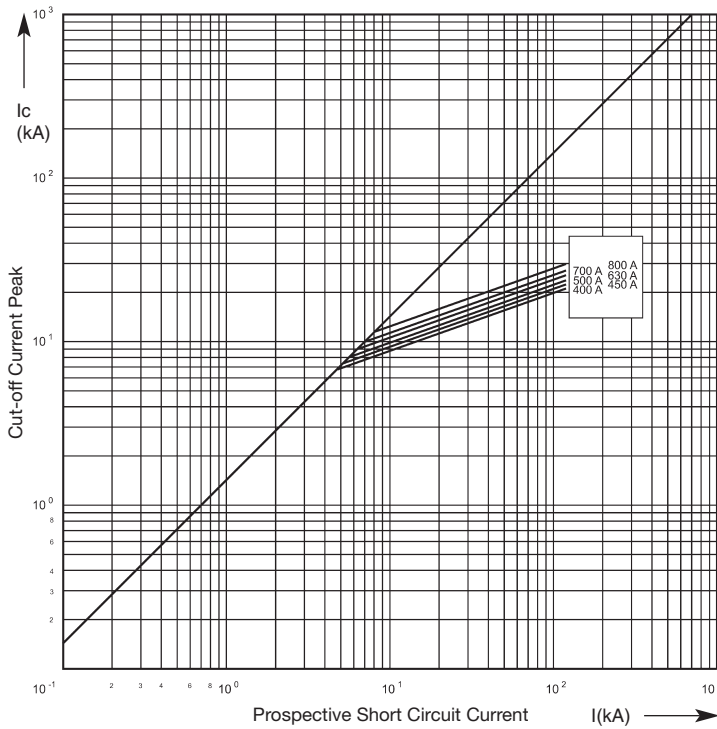

Time-Current Characteristics

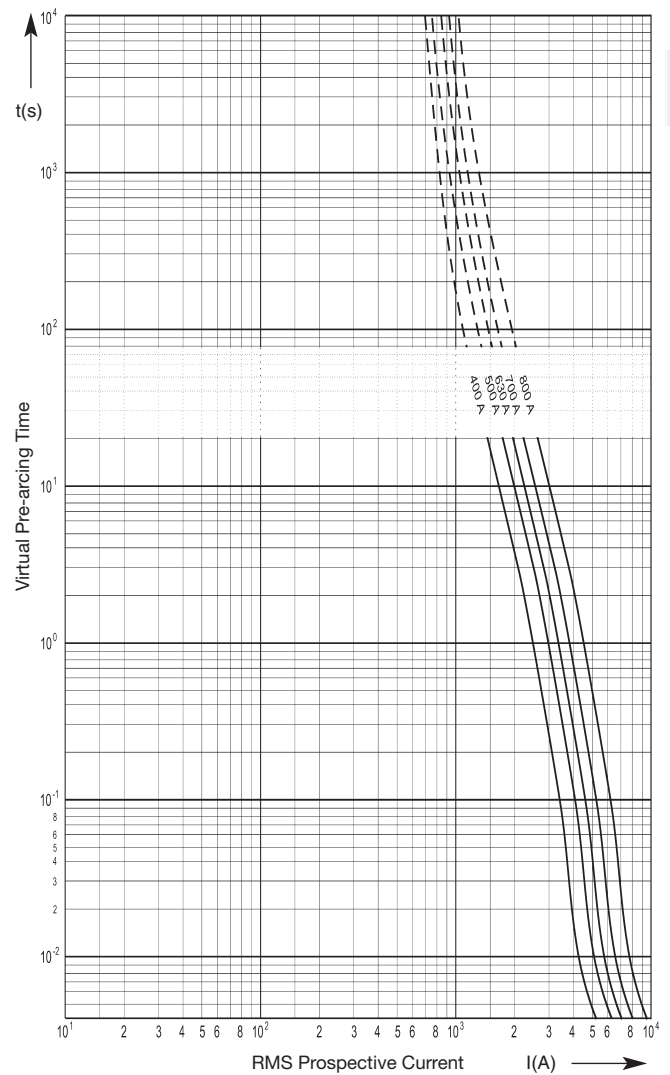

Arc voltage-Diagram

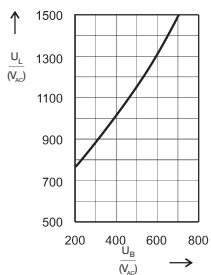

Reduction factor for total I²t-value

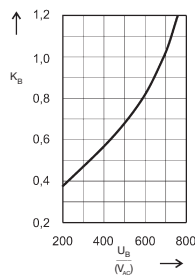

Reduction factor for power loss

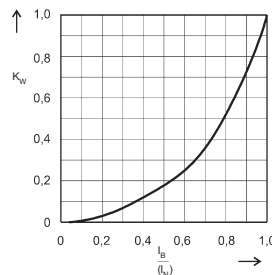

Size
000

Rated Voltage
AC 690/700 V

Operating Class
aR

Rated Breaking Capacity
600 V/300 kA · 700 V/200 kA

Rated Current [A]	Part No.	Part No. without Indicator	Power Loss [W]	Pre-arcing I²t-value [A²s]	Total I²t-value [A²s]
32	20 559 20.32	20 559 21.32	8	52	290
35	20 559 20.35	20 559 21.35	9	66	360
40	20 559 20.40	20 559 21.40	10	90	500
50	20 559 20.50	20 559 21.50	12	140	770
63	20 559 20.63	20 559 21.63	14	250	1 400
80	20 559 20.80	20 559 21.80	18	470	2 600
100	20 559 20.100	20 559 21.100	22	730	4 000
125	20 559 20.125	20 559 21.125	26	1 300	7 200
160	20 559 20.160	20 559 21.160	21	2 800	15 400
180	20 559 20.180	20 559 21.180	35	3 700	20 400
200	20 559 20.200	20 559 21.200	39	4 500	25 000
250	20 559 20.250	20 559 21.250	47	8 000	44 000
315	20 559 20.315	20 559 21.315	58	14 000	77 000

Cut-Off Characteristics

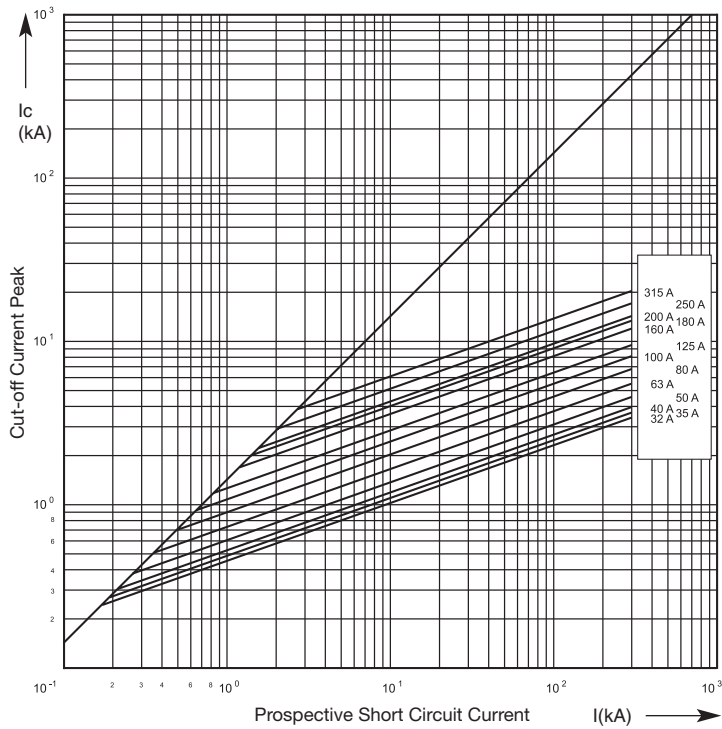

Time-Current Characteristics

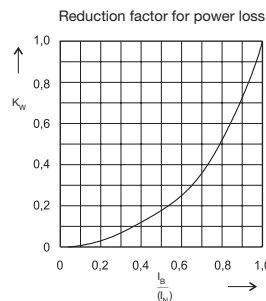
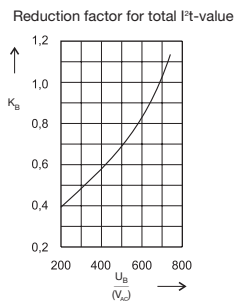
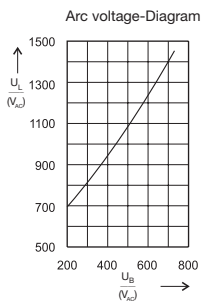
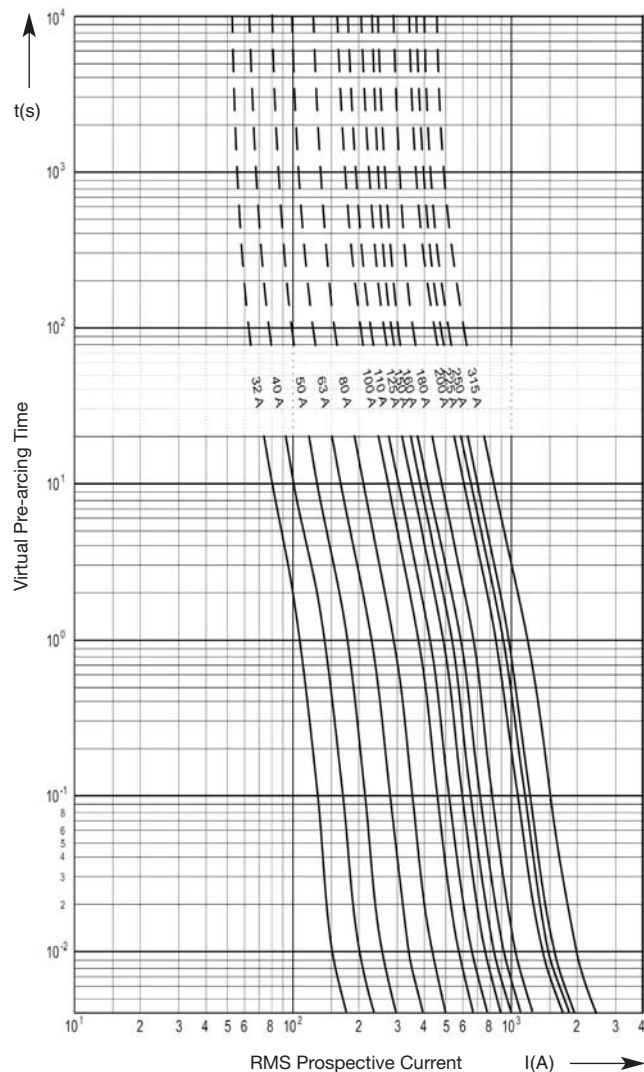

Sets for Indicator Fuses with Micro switch

Part No. Fuse-links	I Set of Clips for Indicator Fuse	II Indicator Fuse	III Micro Switch	H	I	J
50 053 06	58 053 04	58 053 07	58 053 05.1	0.98" (25 mm)	0.87" (22 mm)	0.94" (24 mm)
50 054 06	58 054 04	58 053 07	58 053 05.1	1.60" (41 mm)	1.46" (37 mm)	1.54" (39 mm)
50 073 06	58 053 04	58 073 07	58 053 05.1	0.98" (25 mm)	0.87" (22 mm)	0.94" (24 mm)
50 074 06	58 054 04	58 073 07	58 053 05.1	1.60" (41 mm)	1.46" (37 mm)	1.54" (39 mm)
50 071 06	58 054 07	58 053 07	58 053 05.1	0.98" (25 mm)	0.87" (22 mm)	0.94" (24 mm)
50 075 06	58 054 07	58 073 07	58 053 05.1	1.60" (41 mm)	1.46" (37 mm)	1.54" (39 mm)

